

# OSI Model

- **The model**
- **Functions of the layers**

# Open Systems Interconnection (OSI) Model

- ❑ International standard organization (ISO) established a committee in 1977 to develop an architecture for computer communication.
- ❑ Open Systems Interconnection (OSI) reference model is the result of this effort.
- ❑ In 1984, the Open Systems Interconnection (OSI) reference model was approved as an international standard for communications architecture.
- ❑ Term “open” denotes the ability to connect any two systems which conform to the reference model and associated standards.

# OSI Model

## Layered Architecture

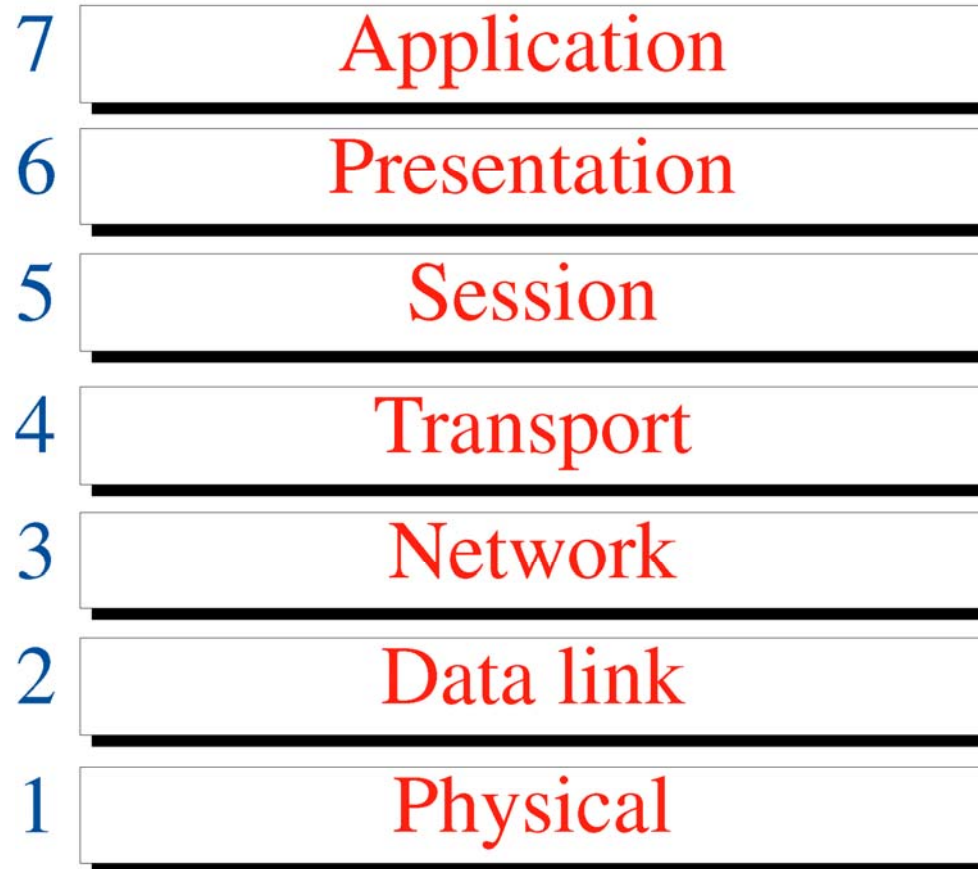

# Benefits of layered Architecture

- ❑ **Layer architecture simplifies the network design.**
- ❑ **It is easy to debug network applications in a layered architecture network.**
- ❑ **The network management is easier due to the layered architecture.**
- ❑ **Network layers follow a set of rules, called protocol.**
- ❑ **The protocol defines the format of the data being exchanged, and the control and timing for the handshake between layers.**

# Organization of the Layers

The Seven layer can be belong from three Subgroups.

Layer 1 (Physical Layer)  
Layer 2 (Data Link Layer)  
Layer 3 (Network Layer)



Network support layers

Layer 4 (Transport Layer)

Layer 5 (Session Layer)  
Layer 6 (Presentation Layer)  
Layer 7 (Application Layer)



User support layers

# The interaction b/w layers in the OSI model

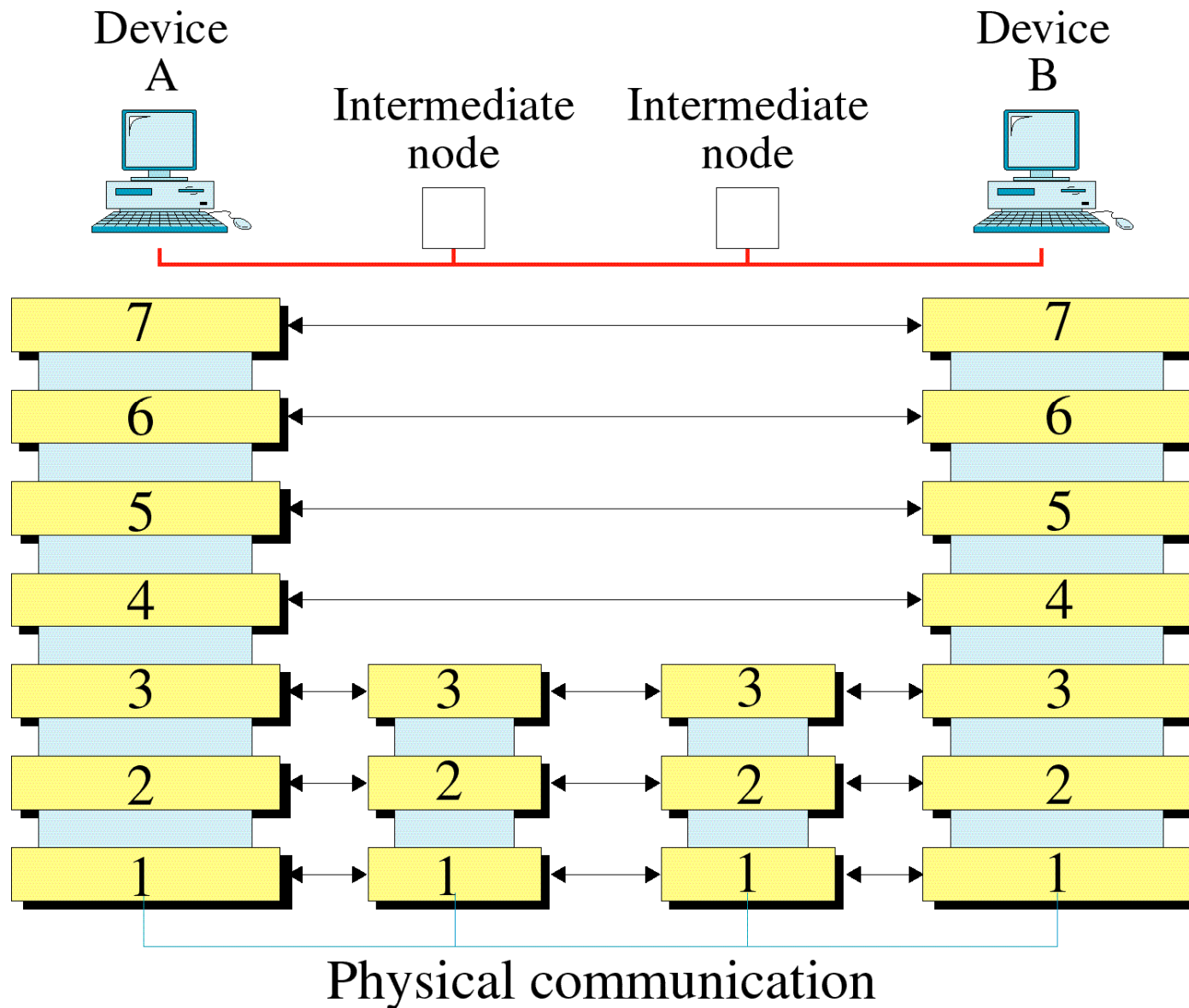

# An Exchange Using the OSI Model

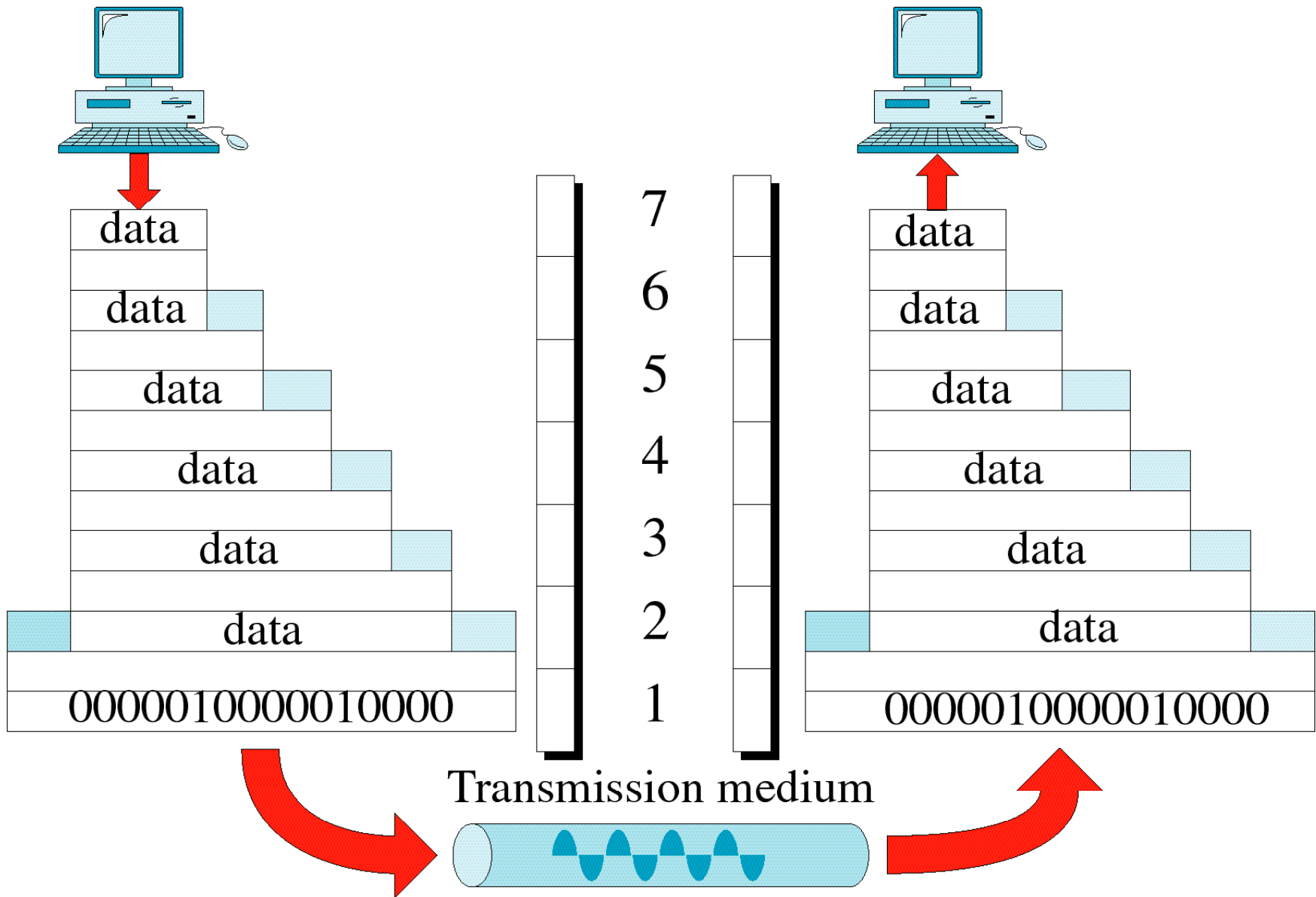

# Physical Layer

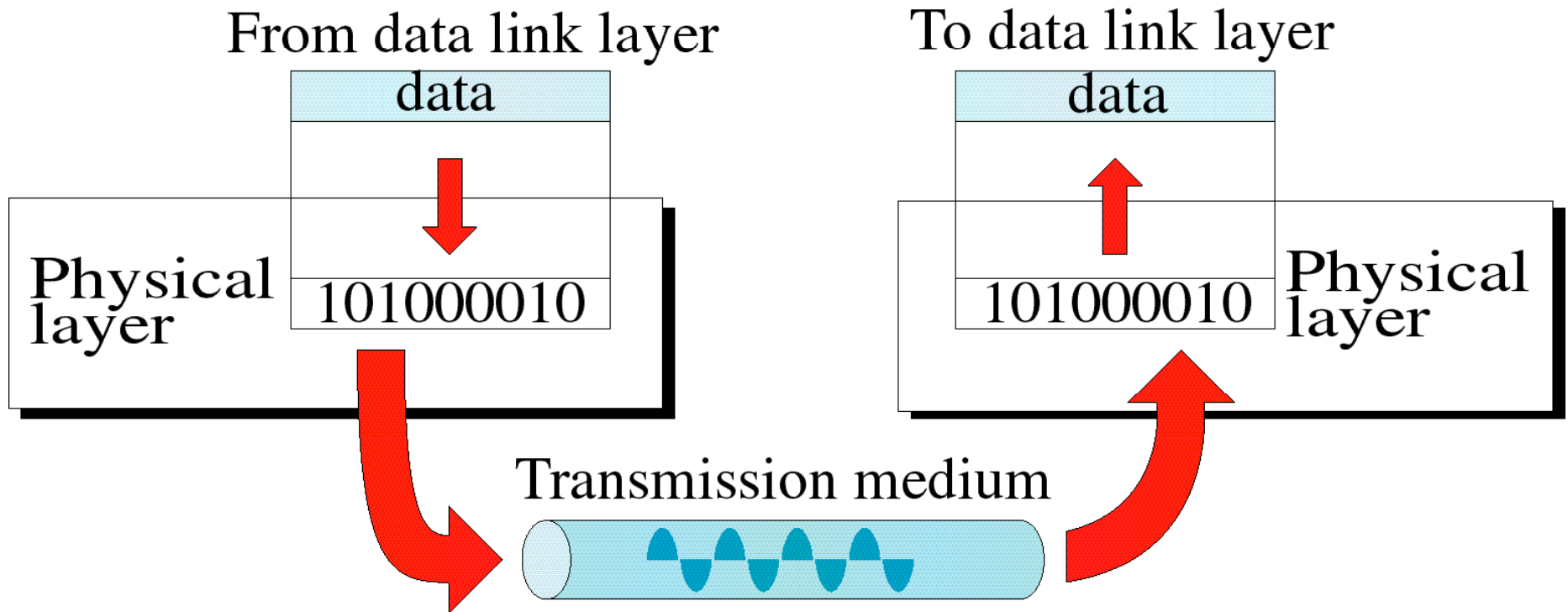



# Physical Layer

The physical layer is concerned with the following

1. Physical characteristics of interface and medium
2. Representation of bit
3. Data Rate
4. Synchronization of bits
5. Line configuration (Type of connection)
6. Physical topology
7. Transmission mode

# Data Link Layer

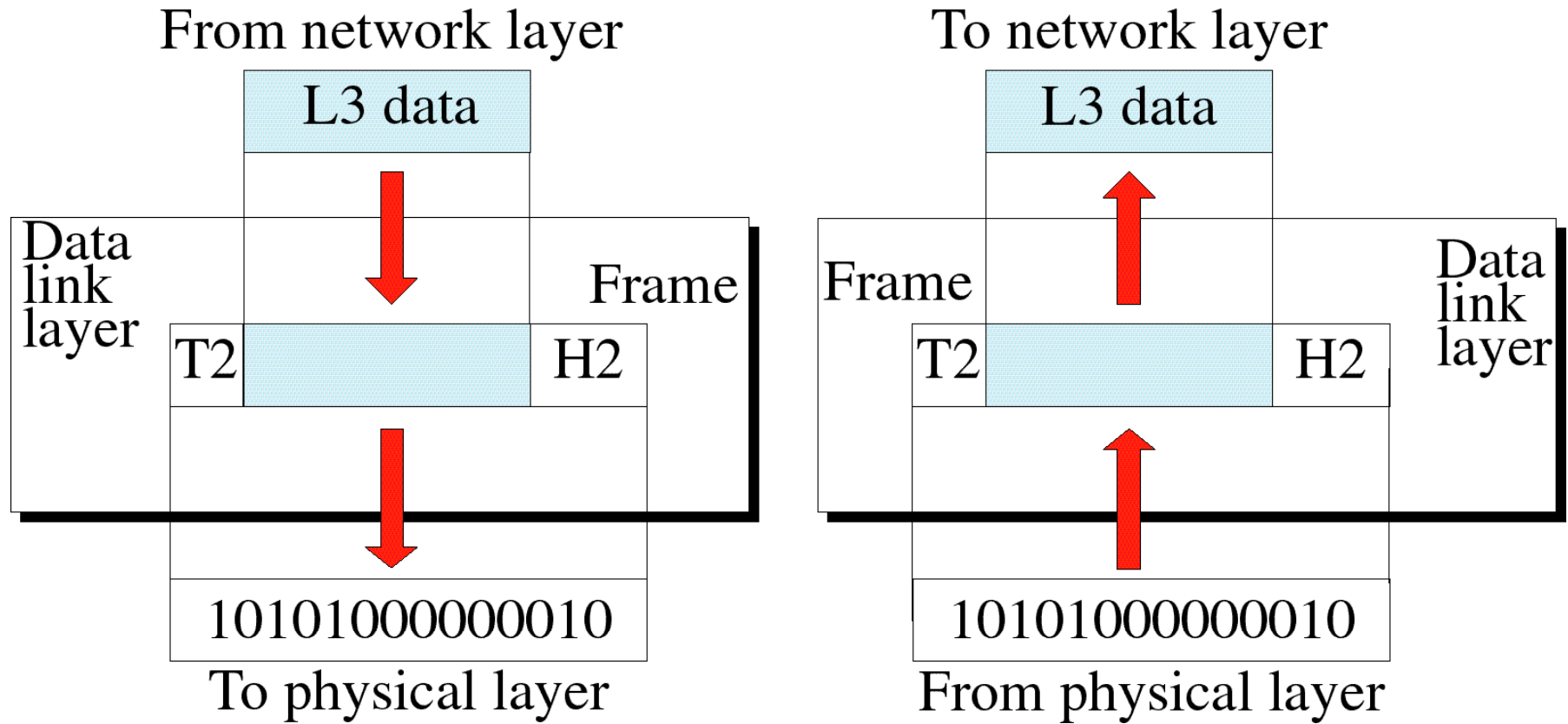

# Data Link Layer

Responsibilities of data link layer

1. Framing
2. Physical address
3. Flow Control
4. Error Control
5. Access control

Figure 3-6

## Data Link Layer Example

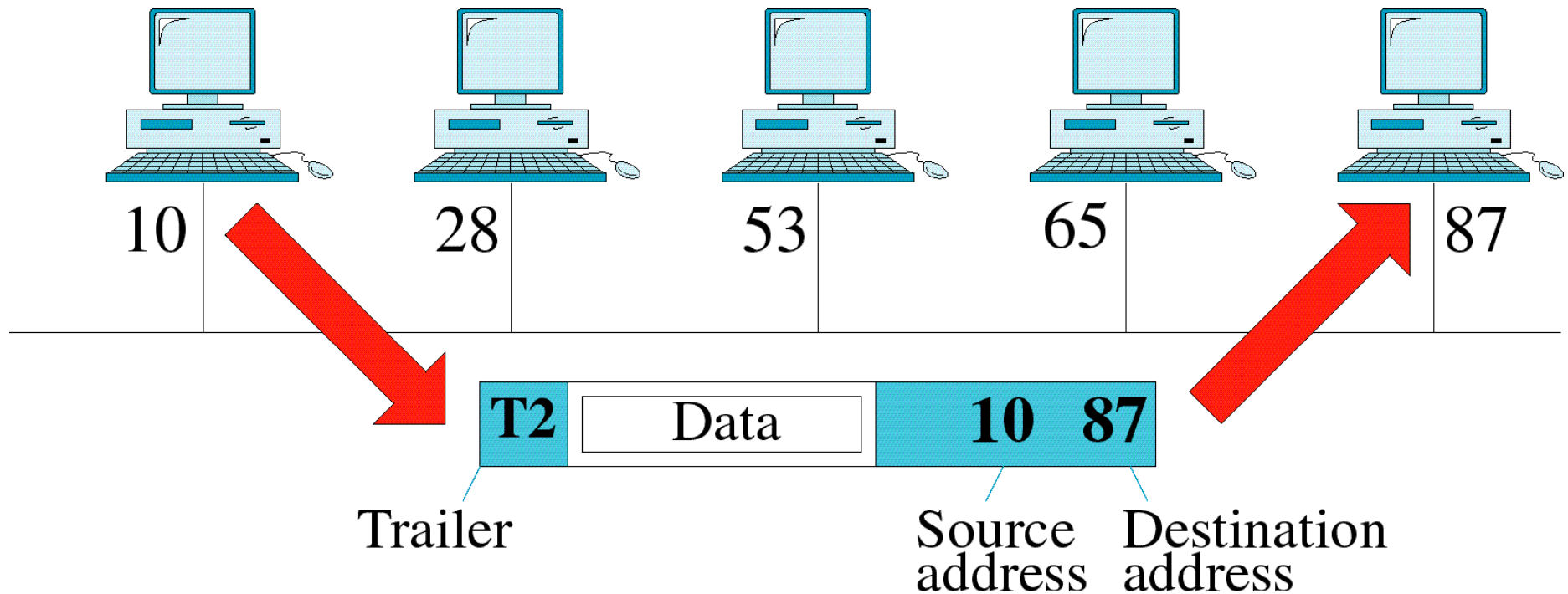

# Network Layer

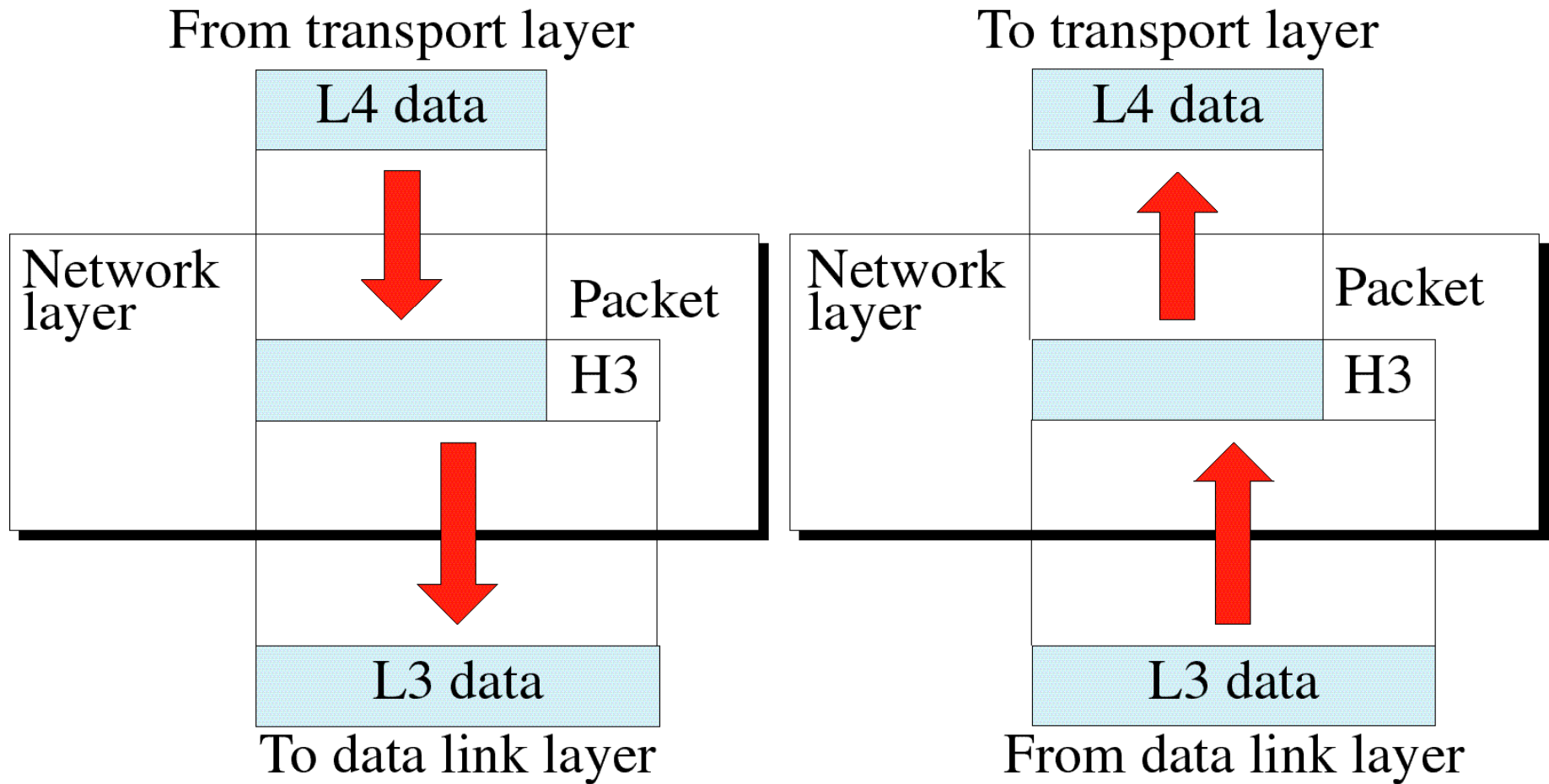

# Network Layer

## Responsibility of the network layer

- ❑ Implements routing of frames (packets) through the network.
- ❑ Defines the most optimum path the packet should take from the source to the destination
- ❑ Defines logical addressing so that any endpoint can be identified.
- ❑ Handles congestion in the network.
- ❑ The network layer also defines how to fragment a packet into smaller packets to accommodate different media.